



FORSVARET  
KYSTESKADREN/MARLOG

# Operativ Logistikk

Strategisk – Operasjonelt – Taktisk

Innlegg på Harlans Seminar 2009

Kommandørkaptein Rune Frømreide  
Sjef Marinens Logistikkvåpen



**“A campaign plan that cannot be logistically supported is not a plan at all, but simply an expression of fanciful wishes”**

**USMC DOCTRINE**



FORSVARET

KYSTESKADREN/MARLOG

# Litt akademia.....

## Inndeling av logistikkbegrepet



Det er selvsagt ingen «vanntette skott» mellom de ulike temaene



FORSVARET  
KYSTESKADREN/MARLOG

# MARLOG

## Kapasitetene 2009





## Utviklingstrekk (2010-14)

- Logbase Sjø overføres til Sjøforsvaret og MARLOG 1 Mai 2010
- Nytt logistikkfartøy planlegges å være operativt 2015



- To mindre fartøy for å støtte praktisk navigasjonstrening på SKSK er under anskaffelse
  - Erstatning KNM Hessa/Vigra med et større fartøy er under planlegging





# Dagens situasjon

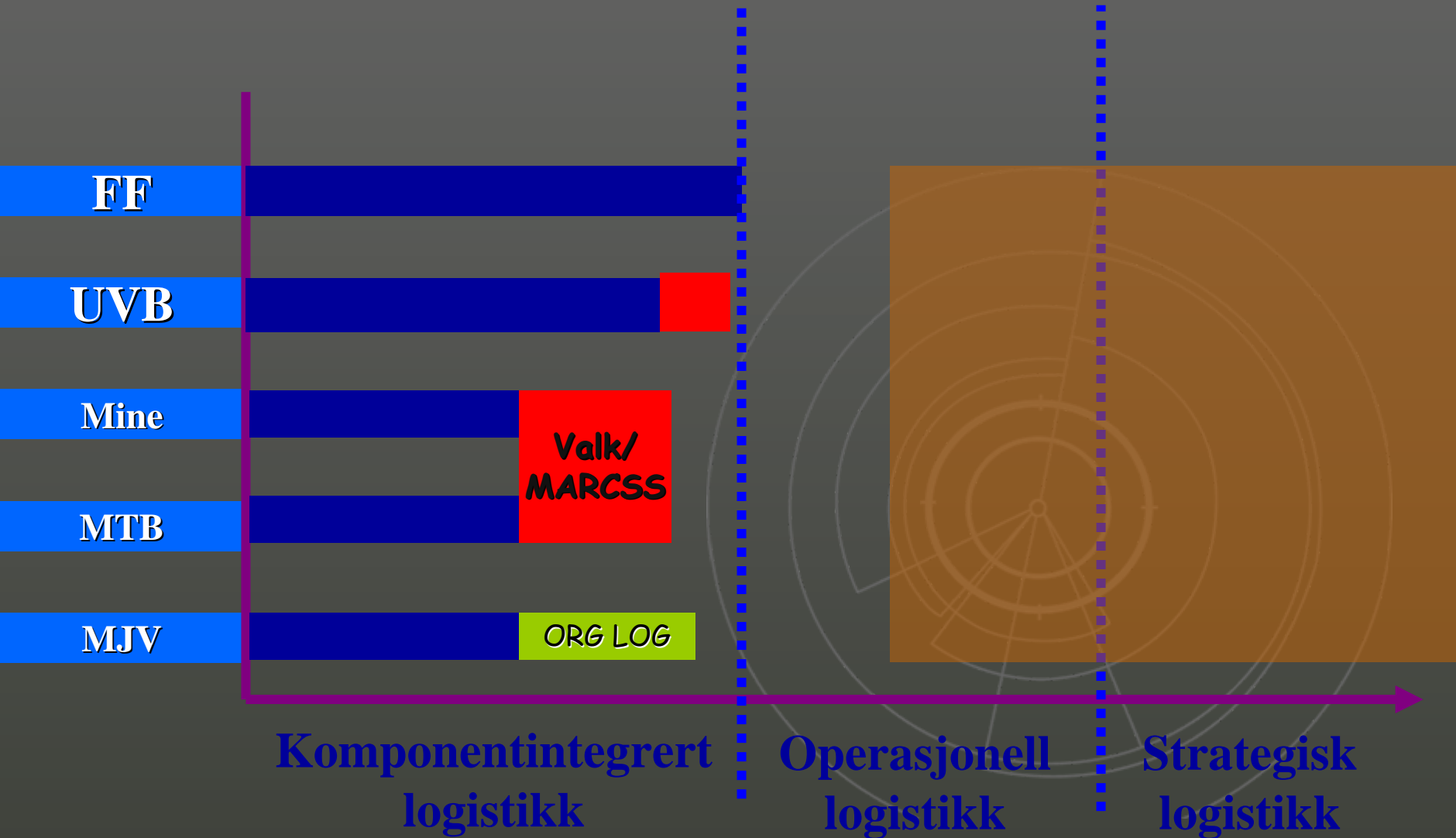



# Fremtiden?

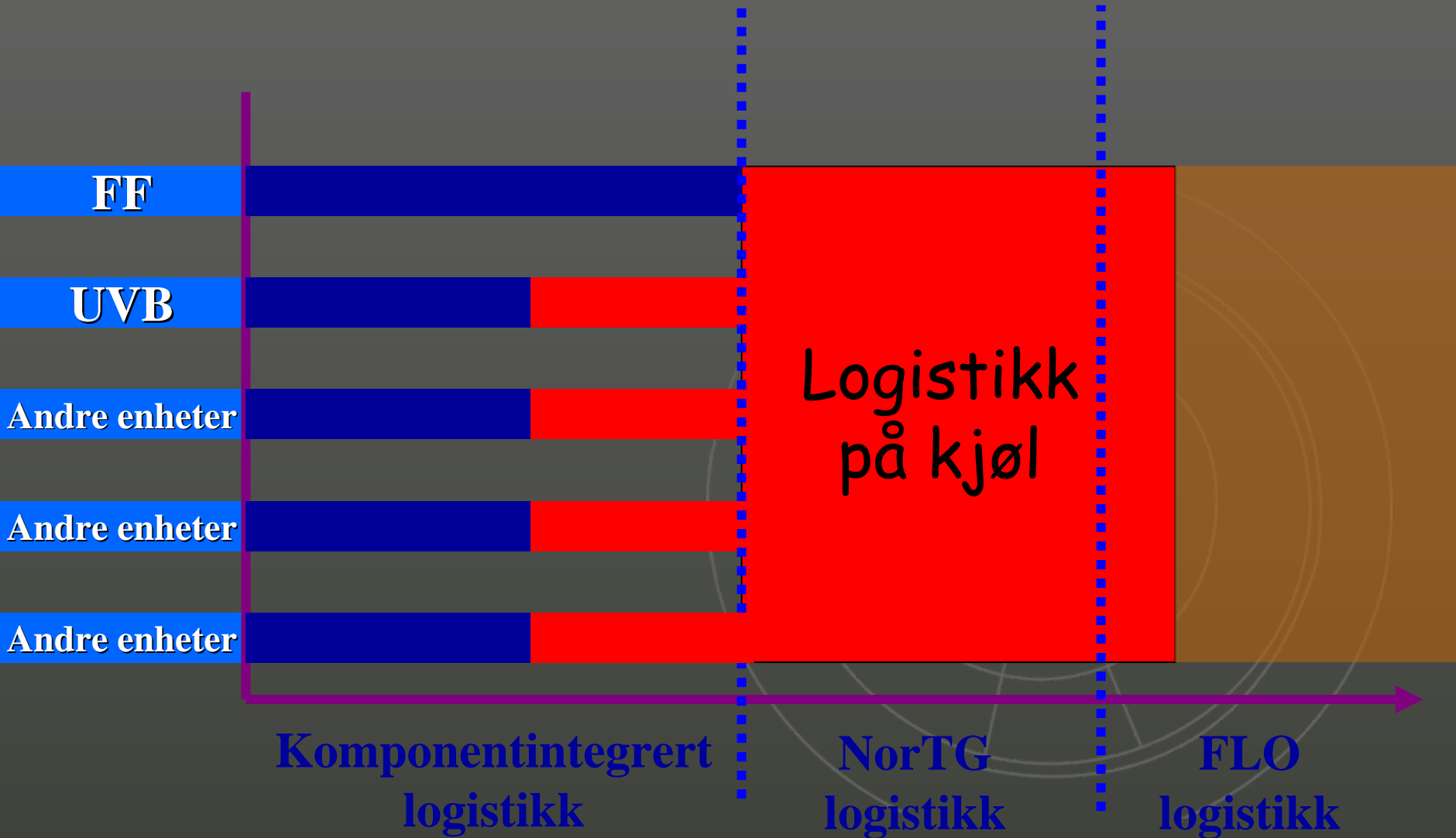



# Maritim operativ logistikk

## Nasjonalt scenario

### Aktør:

- Alle typer

### Strategisk mål:

- Diverse

### Operativt mål:

- Opprettholde normal militær og sivil aktivitet på eget territorium, internasjonalt farvann / luftrom

### Styrkeinnsats:

- Alle typer avdelinger / plattformer

### Gjennomføringstid:

- Til enhver tid

**FFI** Forsvarets  
forskningsinstitutt

NASJONALE SCENARIER  
for  
FORSVARSTUDIET 2007

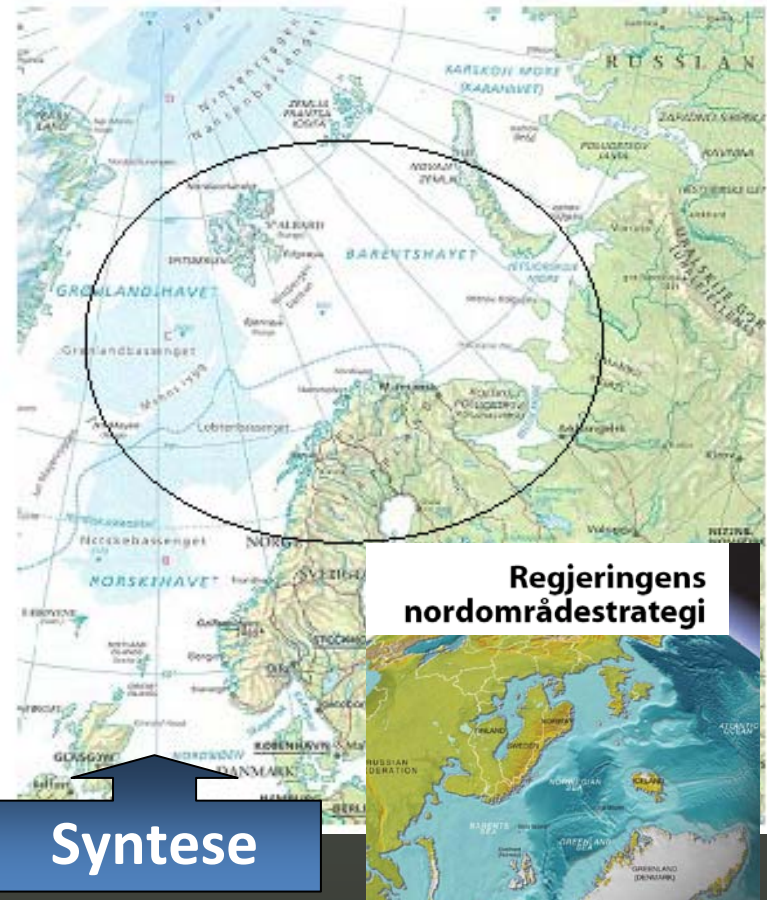



# NIVÅER AV LOGISTIKK PLANLEGGING

MILITÆR  
STRATEGISK

POLITISKE DIREKTIVER  
LOGISTISKE FØRINGER  
HNS MOUs

FD/FST  
(FOH)

OPERASJONELT

SJ FOH ORDRER  
LOGISTISKE FØRINGER  
MARITIME LOGS ORBAT

FOH/J4-9  
MCC/FLC

TAKTISKE

OPORDER  
OPTASK LOG

NORTG  
GLC



# Logistikkbasen og logistikk på kjøl

FLO

Operasjonsområdet

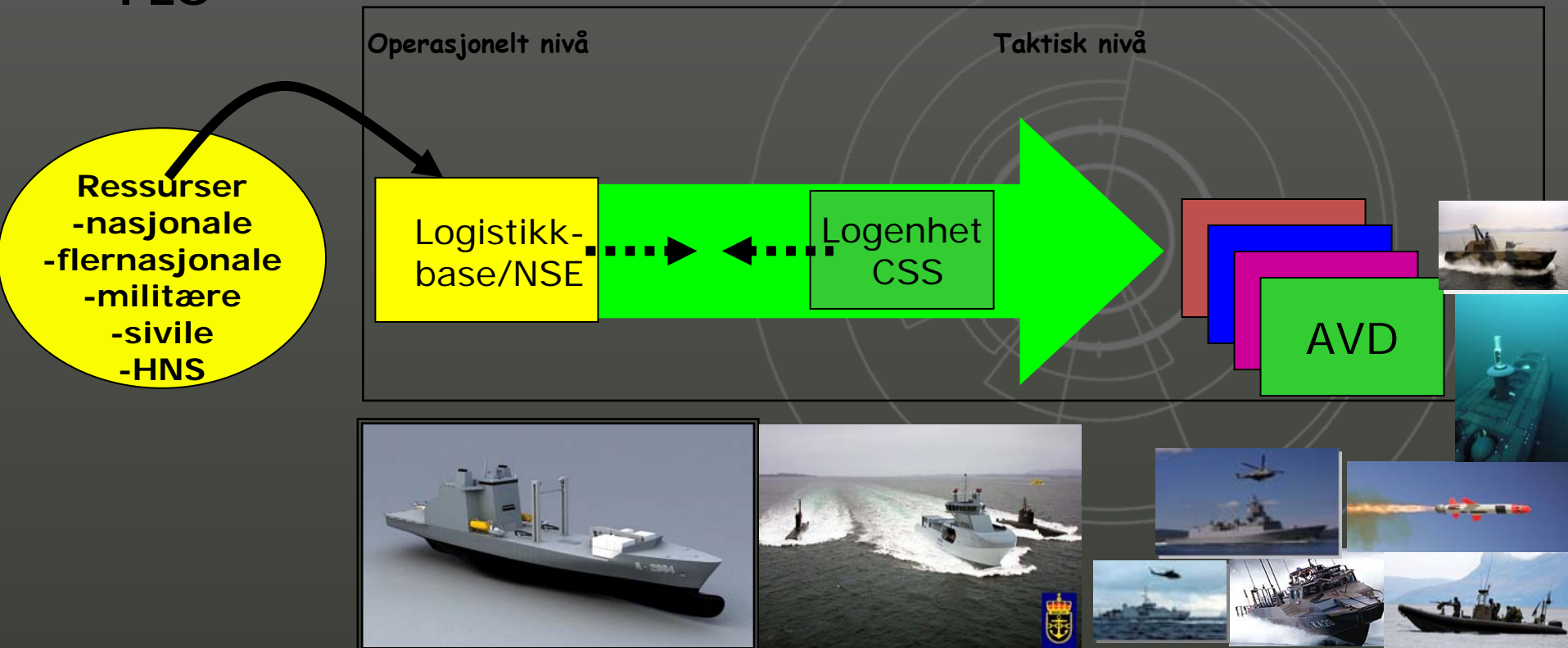



FORSVARET  
KYSTESKADREN/MARLOG



Finance

Recovery



OMAR



HNS



Sanitet





FORSVARET

KYSTESKADREN/MARLOG

# (noen..) Logistikk dokumenter - NATO



**MC 319/2 - NATO Principles and Policies for Logistics**

MC 326/1 - NATO Medical Support, Principles and Policies

MC 327/1 - NATO Military Planning for Peace Support Operations

**MC 334/1 - NATO Principles and Policies for HNS**

**MC 336/2 - NATO Principles, Policies and Concept for Movement and Transportation**

MC 389/1 - Military Committee Policy on NATO's Combined Joint Task Force Capability

**MC 526 Logistic support concept for NATO Response Force (NRF) operations**

**AJP-4.0 LOGISTICS**

AJP-4.4 M & T

AJP-4.5 HNS

**AJP-4.6 MJLC**

AJP-4.9 Multinational Log Sup

AJP-4.10 Medical

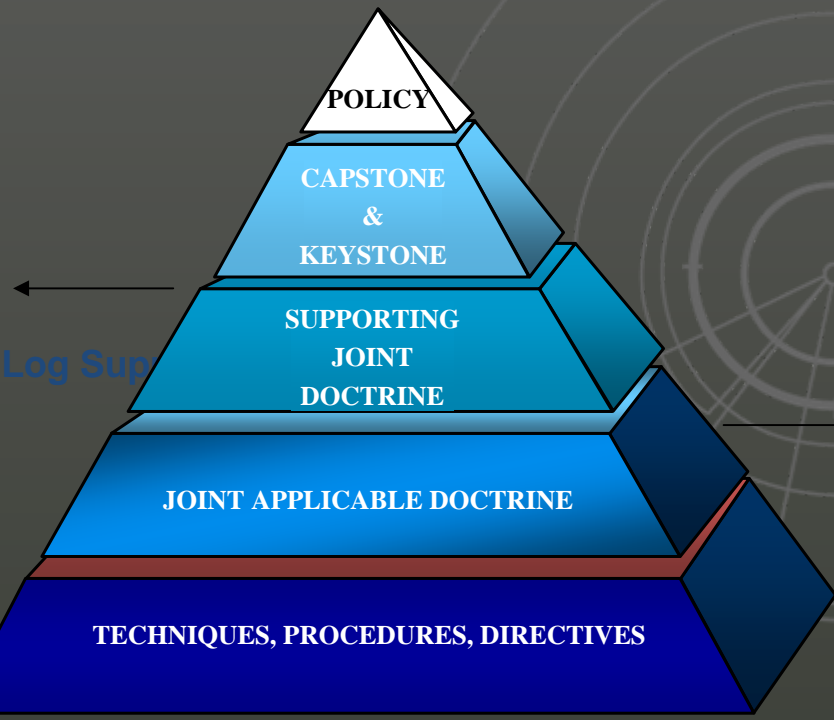

POLICY

CAPSTONE  
&  
KEYSTONE

SUPPORTING  
JOINT  
DOCTRINE

JOINT APPLICABLE DOCTRINE

TECHNIQUES, PROCEDURES, DIRECTIVES

Single service doctr.

ALP-4.1 MARITIME

ALP-4.2 LAND

ALP-4.3 AIR

Bi-SC GOP

Bi-SC FPG

RPG

Bi-MNC Mar Med PG



# Kommando & Kontroll

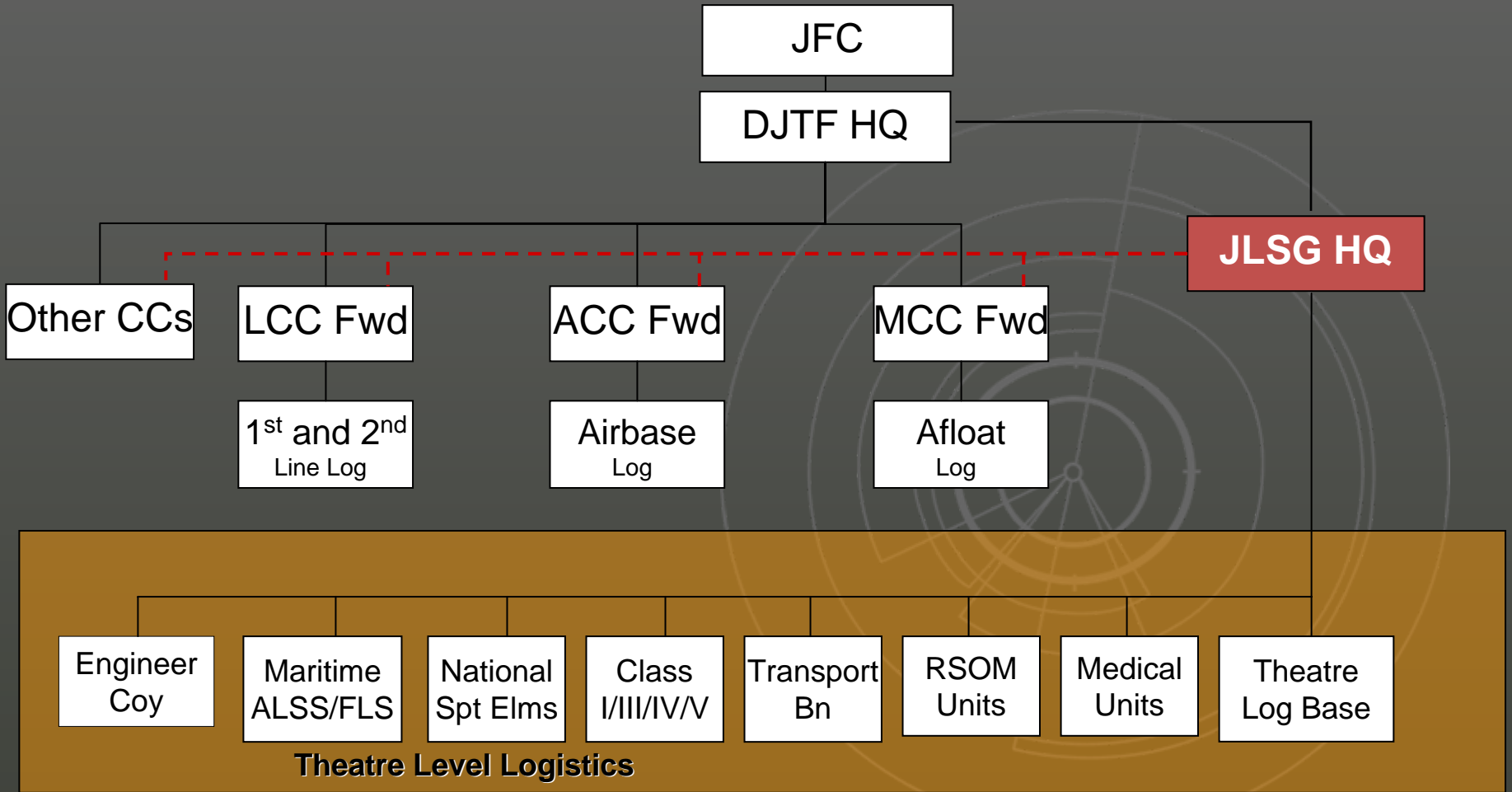



# LOGISTIC SUPPORT TO NATO OPERATIONS

## Options for a mission tailored logistic concept

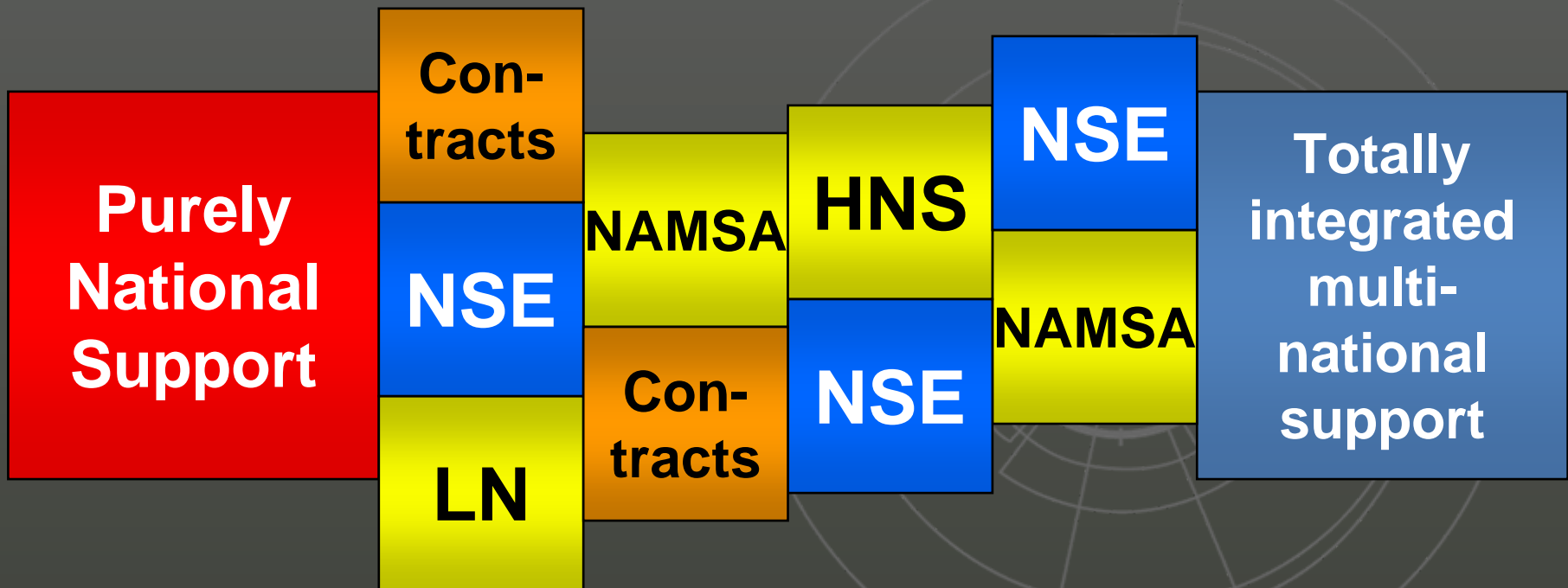

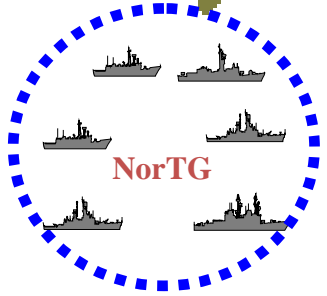
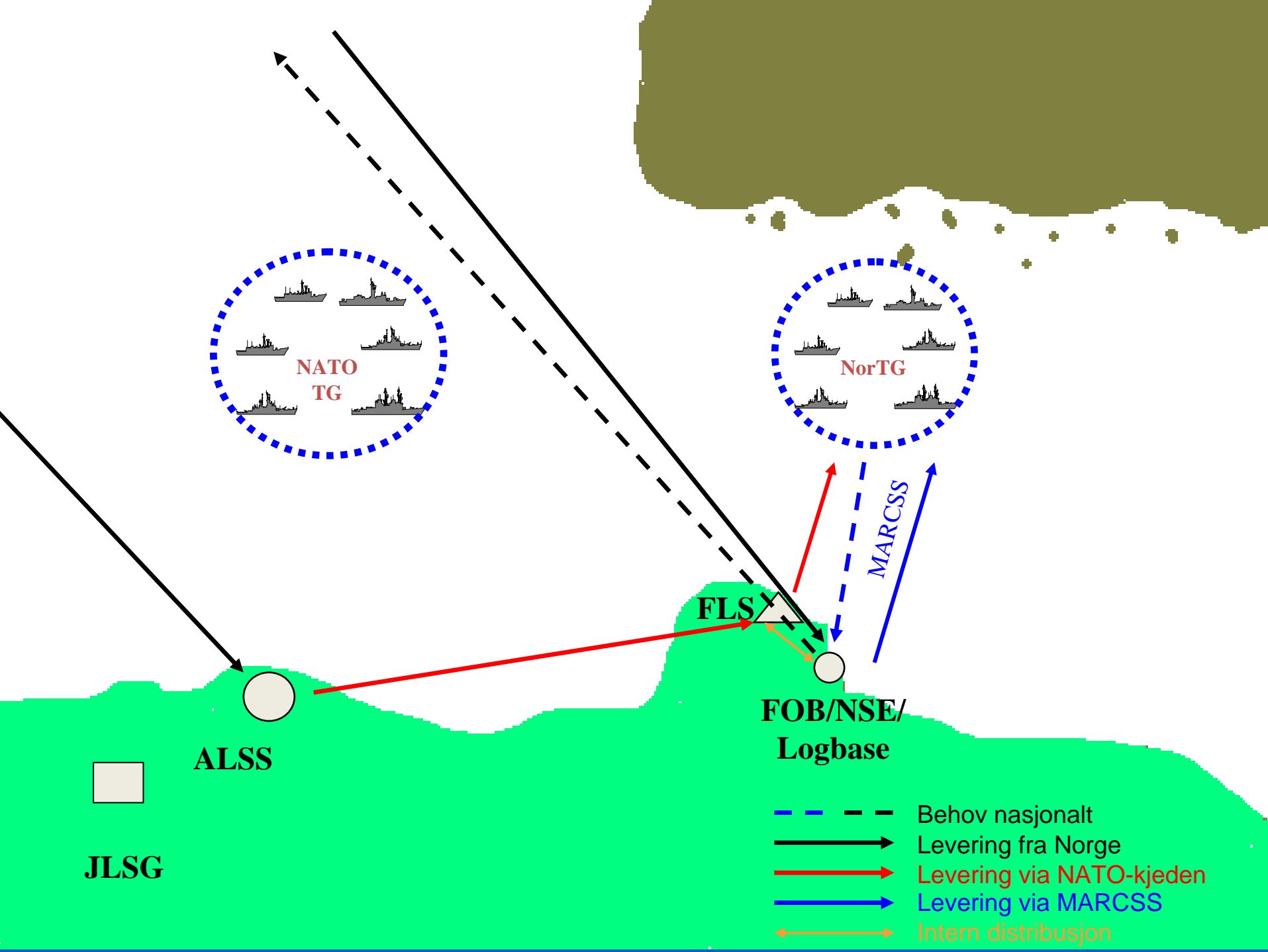

ALSS

JLSG

FLS

FOB/NSE/  
Logbase

MARCSS

- Behov nasjonalt
- Levering fra Norge
- Levering via NATO-kjeden
- Levering via MARCSS
- Intern distribusjon



# JOINT LOGISTIC SUPPORT AREA (JLSA)

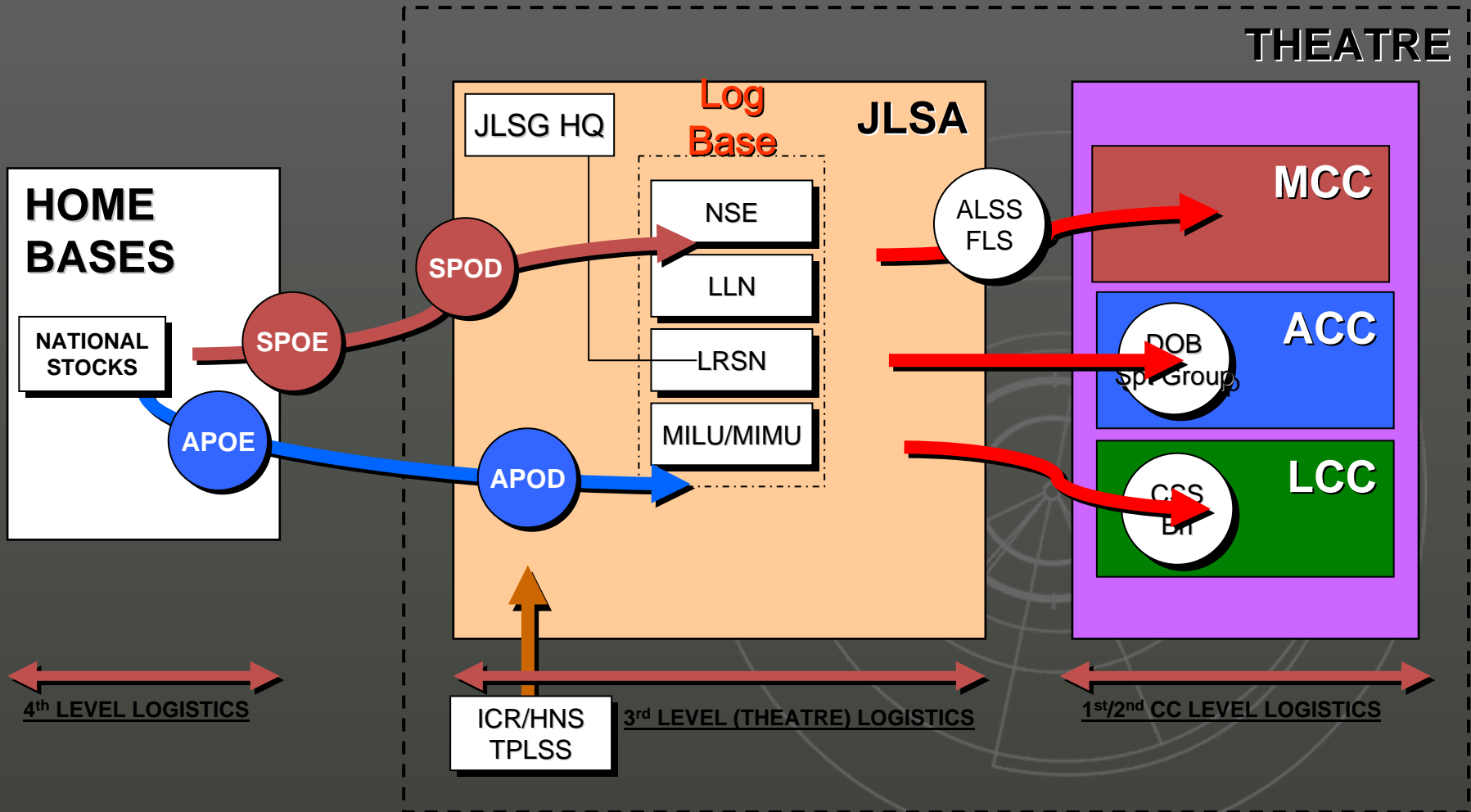



- Erfaringene så langt positiv
  - Banebrytende ift tradisjonell LOG filosofi
  - Mangler enda reell erfaring og doktrinell støtte (ACT)
  - Potensiale for reduksjon av "logistic footprint"
  - Klar styrking av de mindre nasjoners evne til å bidra
  - Større fleksibilitet for styrkesjefen
- Antatt å være basis for fremtidige konsept
  - Revisjon av AJP4 – stoppet opp
  - "Trust & Confidence" må bygges
  - Effektive refusjonsordninger/ordninger for cost share må etableres



- I hvilken grad vil en sann integrert logistikk påvirke nasjonale forberedelser
  - Hvordan trene/kreve plass i JLSG?
  - Grensesnitt FLO/LOGBASE/MARCSS/NSE
  - Hvilke kapasiteter kan tilbys ?
    - personell/materiell/kompetanse
  - Behovet for og betydningen av MOU/TA
  - Hvordan håndtere kontraktører i operasjoner
  - Svært uryddig K2 – COM i praksis liten innflytelse på den viktigste ”enabling” funksjonen - logistikken



FORSVARET

KYSTESKADREN/MARLOG

# Forventinger til fremtiden

## ”..train as you fight”

- Forsvaret og forswarets ansatte må ta logistikken på alvor
  - Gjøre noe med manglene - reservedeler må ikke bli en salderingspost
  - Sann integrert logistikk - være beredt til å ta kostnadene
- Forholde oss til/forpliktet til å benytte doktrinelt fastsatte:
  - Prosesser (GOP)
    - Hær/Luft benytter GOP (Guidelines for Operational Planning)
    - SJØ benytter Commanders Estimate (tilpasset GOP)
  - Prosedyrer (eks rapportering)
    - Nasjonale vs internasjonale rapporteringskrav
  - Metoder & Verktøy (støttesystemer)
    - LOGFAS – TOPFAS systemstøtte
    - Logistikken må inn på et tidligst mulig tidspunkt i planleggingsfasen
- Klarlagte ansvars – og myndighetsforhold innen logistikk
- Norsk bemanning av stillinger i NATO/Pågående operasjoner må reflektere fremtidens økte fokus på logistikk!



# Logistikk-konsept i dag

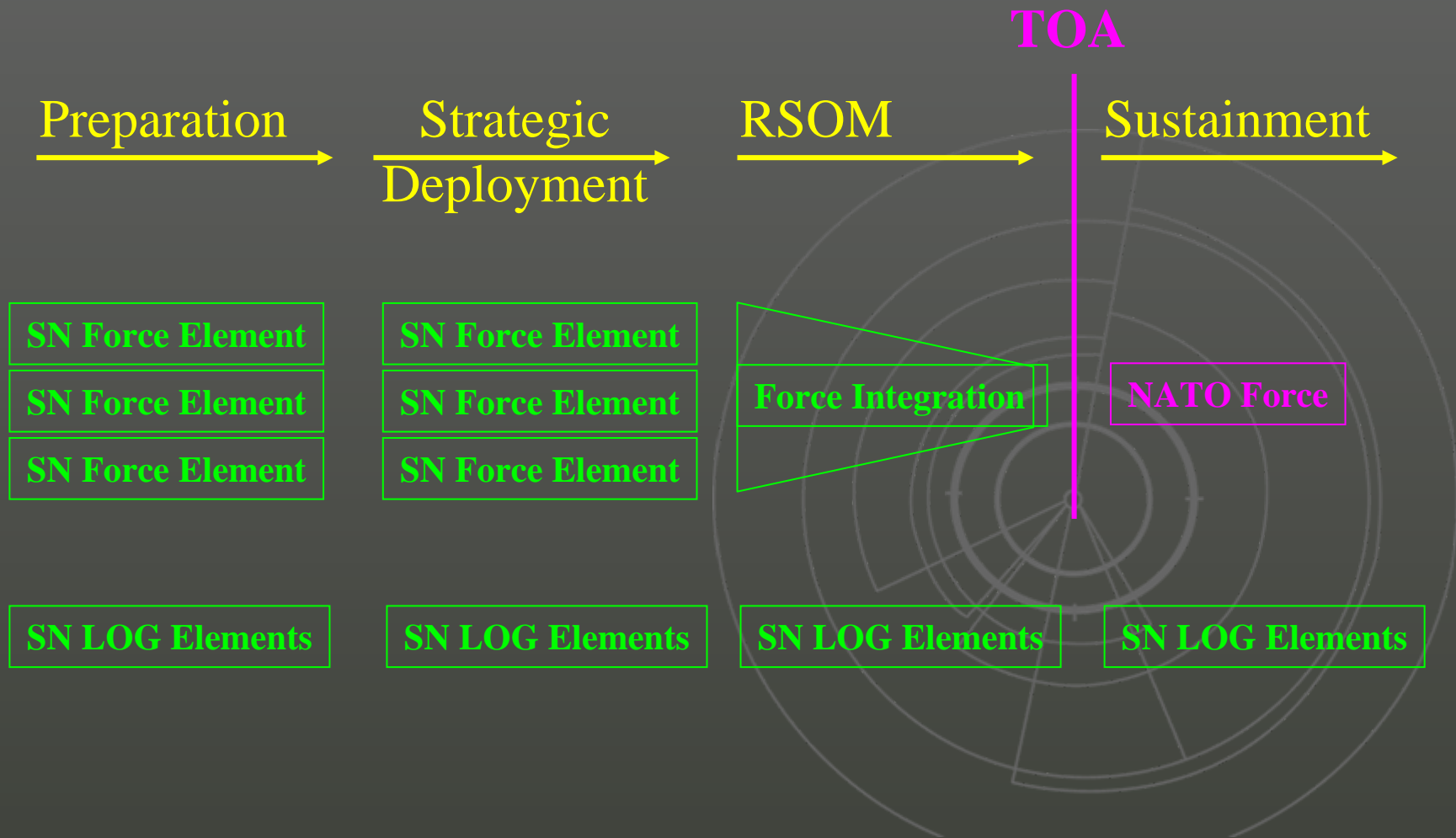



# NRF Logistikk konsept

## TOA

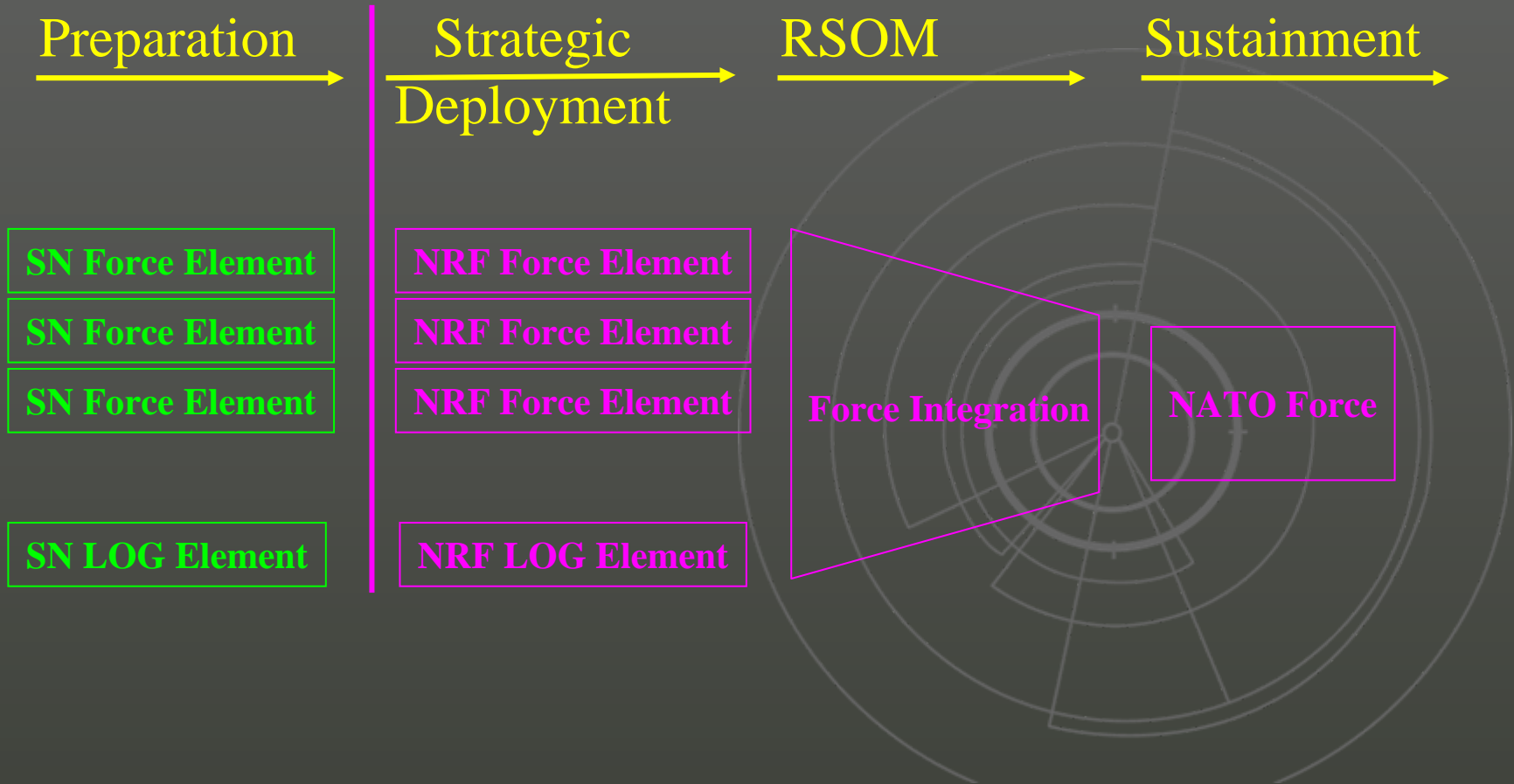



FORSVARET  
KYSTESKADREN/MARLOG

# Marinens logistikkvåpen

- Utholdenhet på havet -

